

- TR**
- PVC cam çıtalarının 45° açıda otomatik kesim işlemi
 - Kalıpsız kullanım imkanı
 - 4 adet HSS testere
 - Dikey pnömatik sıkma sistemi
 - Ayar kolu ile kolay kalıp ayarlama imkânı
 - Çift taraflı 45° açılı kesim sistemi
 - Hızlı ayarlanabilen döner dayama sistemi
 - Panoda bulunan regülatörle kesim hızını kolayca ayarlayabilme imkânı
 - Sol tarafta metreli ve sağ tarafta taşıyıcı konveyör (2,4 m + 2,5 m)

Opsiyon:

- Hızlı ve hassas çıta ölçümü için 2050 mm uzunluğunda çift ölçülü kumpas aparatı

- EN**
- Automatic cutting of glazing bead PVC profiles by 45°
 - Possibility to use without mold
 - 4 HSS cutting saw blades
 - Vertical pneumatic clamping system
 - Setting handle for easy mold adjustment
 - Double side cutting of glazing bead by 45° in one time
 - Rotating support system for quick adjustment
 - Possibility to easily adjust the cutting speed with the regulator on the panel
 - Conveyor system: left (with ruler) and right sides (2,4 m + 2,5 m)

Option:

- Portable mechanical caliper for quick measurements (2050 mm)

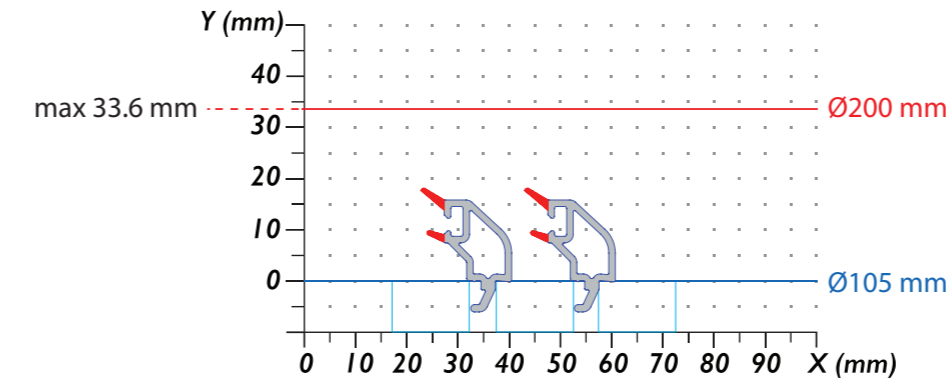
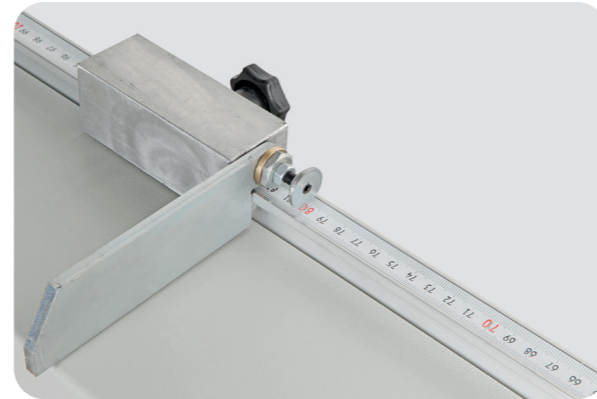
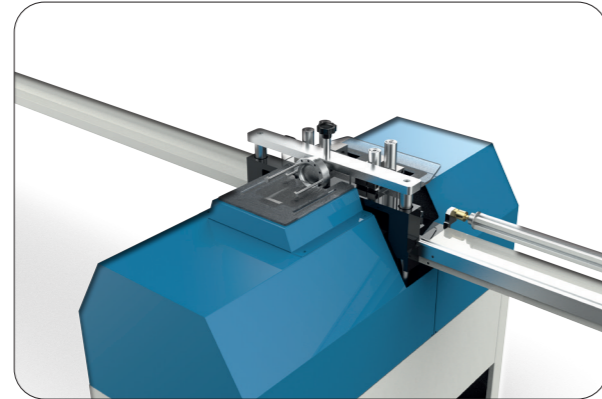
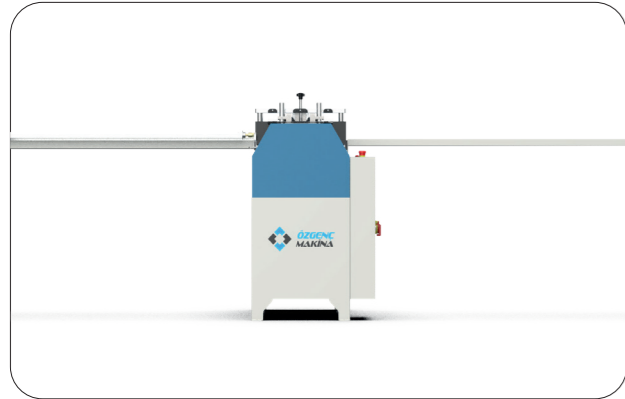
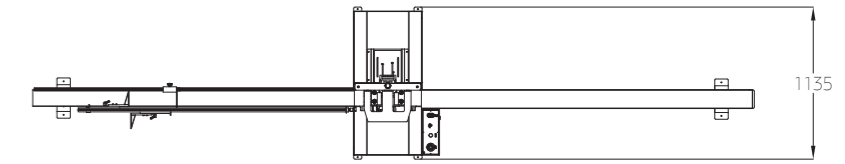
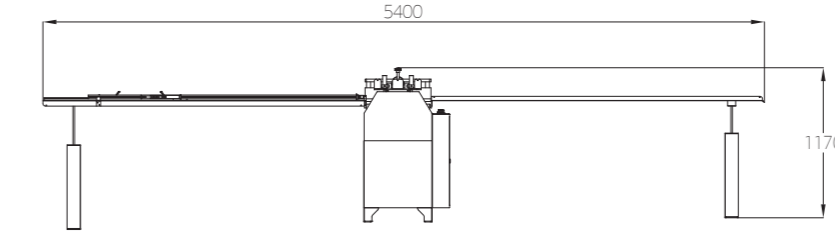

 Hz = 50 rpm = 2780 kW = 2x0,55	 V = 400 kW = 2	 Air 6-8 bar 10 l/bicycle	 kg 200 kg	 H = 1170 mm W = 675 mm D = 1135 mm Conveyor W = 2400 mm D = 380 mm	 ØD1 = 200 mm Ød1 = 32 mm b1 = 1.8 mm Z1 = 160 ØD2 = 105 mm Ød2 = 22 mm b2 = 3 mm Z2 = 90	 L min = 300 mm L max = 2550 mm
--	-----------------------	------------------------------------	------------------	---	---	---------------------------------------