



**ÖZGENC
MAKİNA**



OMRM 113

Automatic Double Head Aluminium Profile Cutting Machine

Designed for PVC and aluminium profiles cutting.

- Cutting length size and angle degree are entered from LCD-display on control panel
- Automatic head position for 45° and 90 °degrees, easy adjustment for intermediate angles
- Memory size of 2299 steps including quantity, length and angles of cuttings
- Possibility of manual length size adjustment
- Magnetic rule length control system
- PLC control system
- Multilanguage support
- Repetitive cut program, angle cut – variable and fixed length – fixed angle
- Extra length cut program (over 4 mt.)
- Diameter of a diamond saw blade is 500 mm
- Output of disk is 170 mm that allows to make double profile cutting (85 mm x 2)
- Horizontal pneumatic clamping kit
- Adjustable cutting speed

- Single head operation possibility
- Industrial dust exhaust
- Bearing conveyor for the movable head
- Intermediate profile support for long size cutting
- Particular care has been taken over the safety measures, both mechanical and electrical

Option:

- Cooling system for aluminium profile cutting
- Data transfer module from computer to machine via ethernet and barcode label printer

Technical Specifications

- Power Supply: 380-400 V, 3 ph, 50-60 Hz
- Spindle speed : 3000 rpm
- Total KW : 6 kW
- Air pressure : 6-8 bar
- Air Consumption : 11 lt/min
- Machine Height : 1780 mm
- Machine Length : 5220 mm
- Machine Width : 1720 mm
- Machine Weight : 1170 Kg
- Saw Outside Diameter : Ø500
- Inside Diameter of Saw : Ø30
- Saw Thickness : 4,2 mm
- Number of Teeth : 120
- Machinable Minimum Profile Length : 500 mm
- Machinable Maximum Profile Length : 4000 mm

5200

1862

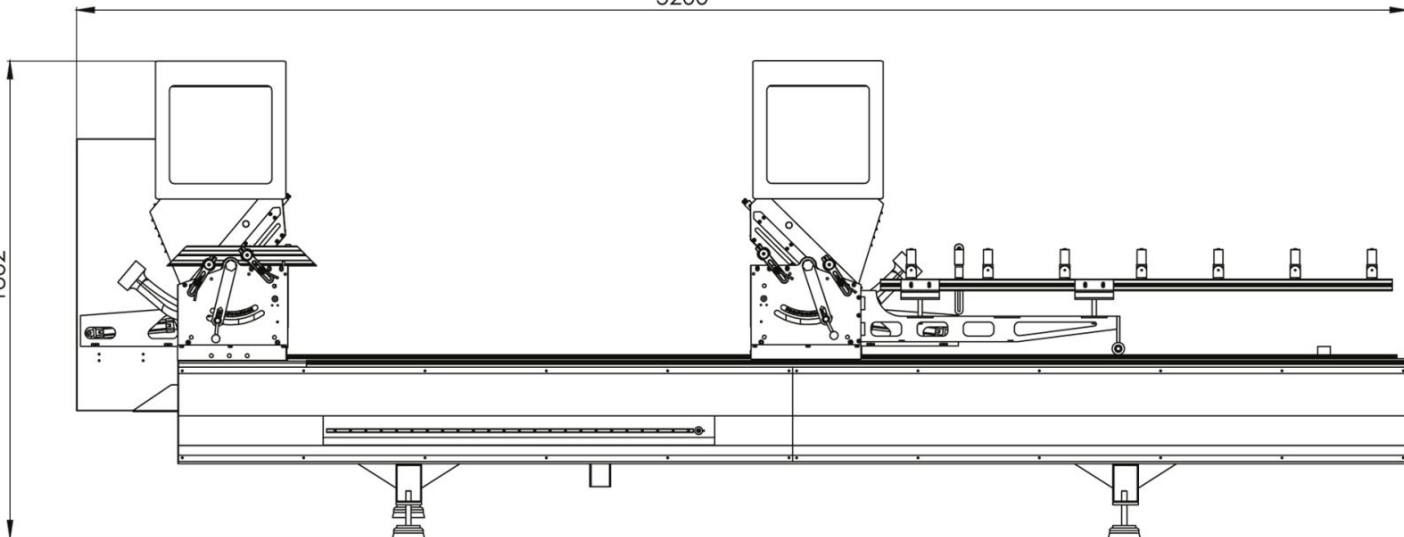

1230

